

ELEVATION

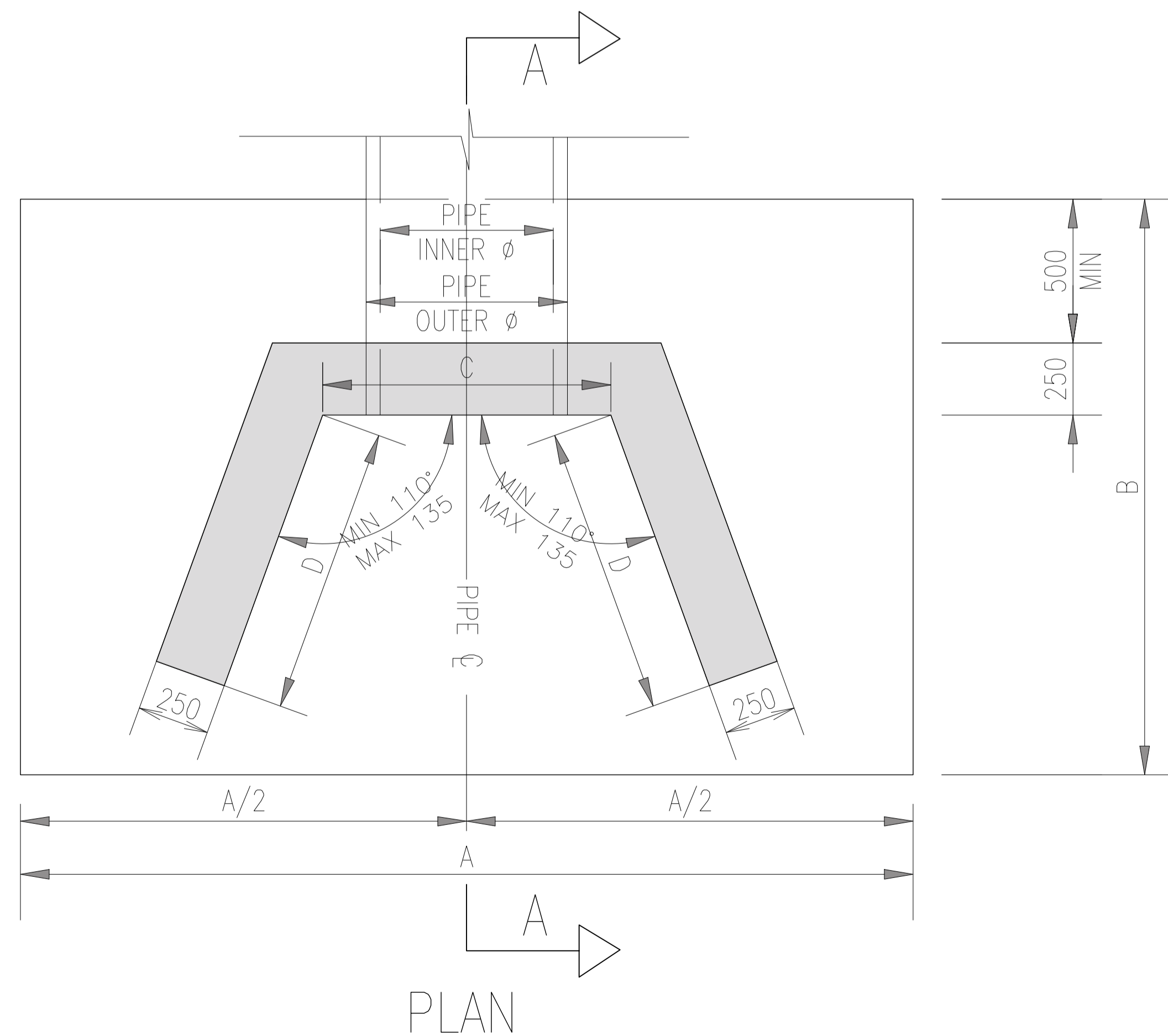

PLAN

SCHEDULE OF MINIMUM DIMENSIONS						
PIPE INNER ϕ	A	B	C	D	E	F
≤ 300	2000	2000	PIPE OUTER $\phi + 300$	1000	400	500
301-600	2500	2500	PIPE OUTER $\phi + 300$	1250	400	600
601-900	3200	3200	PIPE OUTER $\phi + 300$	1550	500	700
901-1200	3900	3900	PIPE OUTER $\phi + 300$	1850	500	800
1201-1500	4700	4700	PIPE OUTER $\phi + 300$	2150	500	900
1501-1800	5200	5200	PIPE OUTER $\phi + 300$	2350	500	1000

THE DIMENSIONS CONTAINED IN THE TABLE ABOVE ARE MINIMUMS ONLY AND THE DESIGNER SHALL CONFIRM DETAILS FOR SPECIFIC SITE CONDITIONS. THE DIMENSIONS CONTAINED IN THE TABLE ABOVE ARE BASED ON THE FOLLOWING CONSTRAINTS:

- ANGLE BETWEEN HEADWALL AND WINGWALL IS 110°;
- BACKFILL MATERIAL IS FREE DRAINING;
- THERE ARE NO LIVE LOAD EFFECTS ON THE HEADWALL;
- CHARACTERISTIC VALUE OF INTERNAL FRICTION (ϕ) OF THE BACKFILL MATERIAL = 37.5°;
- 600mm COVER TO THE PIPE AT THE REAR OF THE HEADWALL, WITH A 200mm WIDE FLAT AREA BEFORE THE COMMENCEMENT OF THE MAIN EARTHWORKS SLOPE;
- SLOPE OF FILL MEASURED FROM THE REAR FACE OF THE WINGWALLS DOWNWARDS AND FROM BED LEVEL UPWARDS ARE BOTH TO BE 1:1

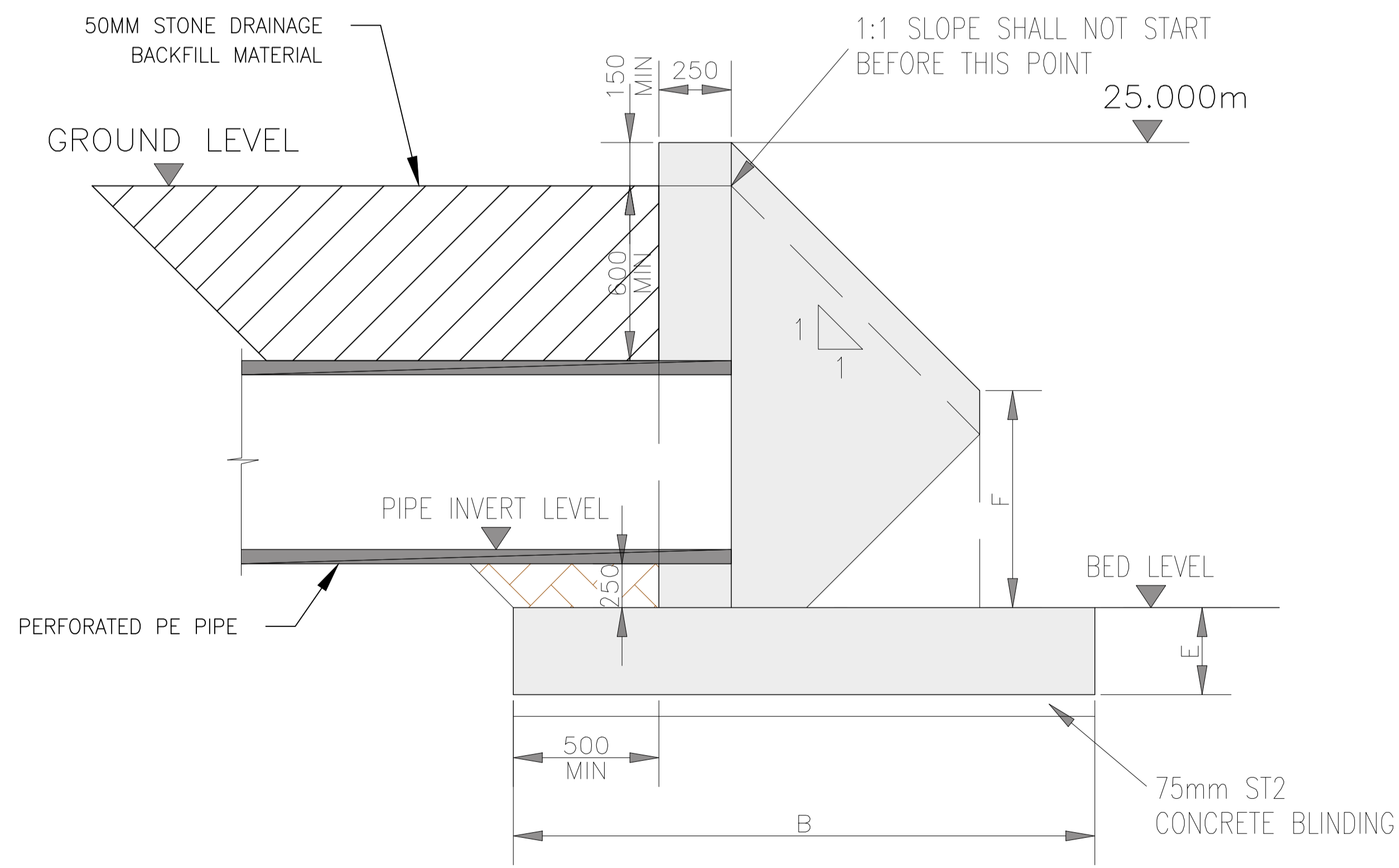

SECTION A-A

NOTES:

All dimensions in millimeters.
Do not scale from drawing.
For any discrepancies found please consult with design office.
This drawing should be read in conjunction with all contract drawings, documents and specifications.

1. This RCD is only to be used in association with a unique structural design. This design is to be carried out in accordance with the NRA requirements for the use of Eurocodes for the design of road structures.
2. Reinforced concrete shall be a minimum grade of C32/40. All structural concrete shall be specified in accordance with Series 1700 of the NRA MCDRW.
3. All blinding concrete shall be ST2 in accordance with IS EN 206
4. The minimum cover to reinforcement for durability shall be in accordance with NRA BD 57. Minimum exposure class to be XC4.
5. Any resulting void between the outside of the pipe and the OPE in the headwall shall be filled with non-compressible high strength grout.
6. All exposed concrete surfaces from 100mm below ground level to be class U4/F4 finish. All other concrete surfaces to be class U1/F1 finish unless otherwise specified
7. Headwall wingwalls to be sloped and shall maintain a minimum height of 150mm above adjacent backfill level.
8. Rendered concrete blockwork may be used as an alternative to in-situ or precast concrete for pipes up to 300mm inner diameter.
9. All headwalls shall be backfilled with class 6N1, 6N2 or 6P backfill material. Headwalls shall be founded on a minimum 75mm layer of ST2 blinding concrete. Details of the sub-base layer to be confirmed based on site conditions.
10. Rock armour and/or Gabion headwalls and wingwalls are prohibited.

Rev	By	Date	Description
01	SM	28/07/21	Adjusted dimensions
02	SM	31/08/21	Modified text

Drawing Status: PLANNING
NOT CERTIFIED FOR CONSTRUCTION

Project Title: Cloghroe Development

Drawing Title: Outfall Headwall Standard Details

Client: Cloghroe Development Ltd.

M.H.L. & Associates Ltd.
Consulting Engineers
Carrige Mór House,
10 High Street,
Douglas Road,
Cork
Tel: 021-4840214
Fax: 021-4840215
E-Mail: info@mhl.ie

Designed: SM	Drawn: SFM	Checked: KM
Scale: N.T.S	Date: June 2021	
Job No: 19083HD	Drawing No: RL1-SCD-P07	Revision: 02